

# Automatic Wall-mounted Mixer SLU 25



SLU 25

## Characteristics:



- economical aerator, rate of flow 6 l/min
- suitable for medical facilities
- function of automatic water stop after 5 minutes of continuous flow
- mixers are destined for cold and hot water, water temperature is regulated by automatic thermostatic mixer, pressure of hot and cold water must be the same
- water is flowing as long as hands are in the active range (max. range to 0,3 m)
- water stops flowing after removal of hands from the active range of sensor after adjustable time delay
- adjustable time delay from 0,25 to 7,75 sec.
- possibility of changing of time delay, active range and switching off by SLD 03
- safety fuse against scalding
- monitoring of battery capacity (only for models with „B“ index)
- START/STOP program

## Technical Specification:

SLU 25, SLU 25B	water inlet spacing 150 mm
Operating voltage	
- SLU 25	24V DC
- SLU 25B	battery 9V
Power input	
- operating voltage 24V DC	3 W
- operating voltage 9V	2 W
Battery life	
- lithium 9V, typ U9VL	approx. 2 years (100 uses per day)
Active range	
- standard	0,07 - 0,4 m
- START/STOP program	0,05 - 0,15 m
Recommended flow pressure	0,1 - 0,6 MPa
Rate of flow	6 l/min. (inf. data)
Water inlet	male thread G 1/2"
Water outlet	swivel spout
Temperature regulation	by automatic thermostatic mixer

## Installation Drawing:

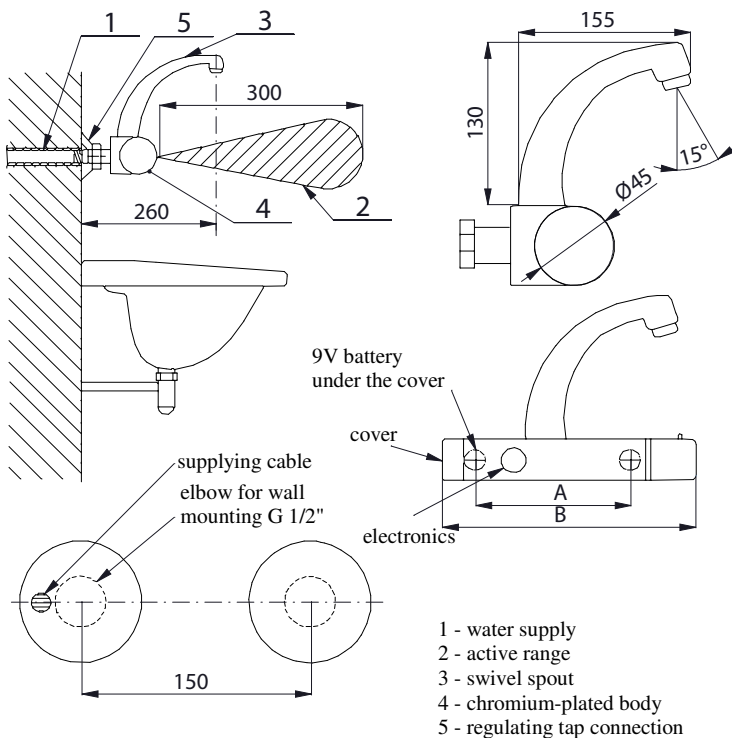

## Supply Specification:

<b>SLU 25</b>	- supply No. 03250	chromium-plated faucet with an integrated electronics; built-in thermostatic mixer and electromagnetic valve (1 pc.); regulating tap connection (2 pcs.); chromium-plated cover (2 pcs.); swivel spout (chromium-plated); filter (2 pcs.); lithium battery SLA 09
<b>SLU 25K</b>	- supply No. 13257	
<b>SLU 25B</b>	- supply No. 03255	
<b>SLU 25BK</b>	- supply No. 13254	(only for models with „B“ index)

## Recommended Accessories:

<b>SLZ 01Y</b>	- supply No. 05012	external power supply 230/24V DC for operating of max. 2 pcs. of washbasin taps
<b>SLZ 01Z</b>	- supply No. 05011	external power supply 230/24V DC for operating of max. 4 pcs. of washbasin taps
<b>SLZ 03</b>	- supply No. 05030	switched power supply 230/24V DC for operating of max. 9 pcs. of washbasin taps
<b>SLZ 06</b>	- supply No. 05060	external power supply 230/24V DC for operating of max. 1 pc. of washbasin taps
<b>SLZ 04Y</b>	- supply No. 05041	external power supply 230/24V DC on DIN rail, for operating of max. 5 pcs. of washbasin taps
<b>SLZ 04Z</b>	- supply No. 05042	external power supply 230/24V DC on DIN rail, for operating of max. 9 pcs. of washbasin taps
<b>SLZ 04X</b>	- supply No. 10049	external power supply 230/24V DC on DIN rail, for operating of max. 15 pcs. of washbasin taps
<b>SLD 03</b>	- supply No. 07030	universal remote control for an adjustment of parameters of all products with infra-red electronics
<b>SLA 09</b>	- supply No. 06090	lithium battery 9V/1200 mAh, type U9VL, battery life approx. 2 years at 100 uses per day (only for models with „B“ index)