

Automatic Washbasin Mixers SLU 18, SLU 28

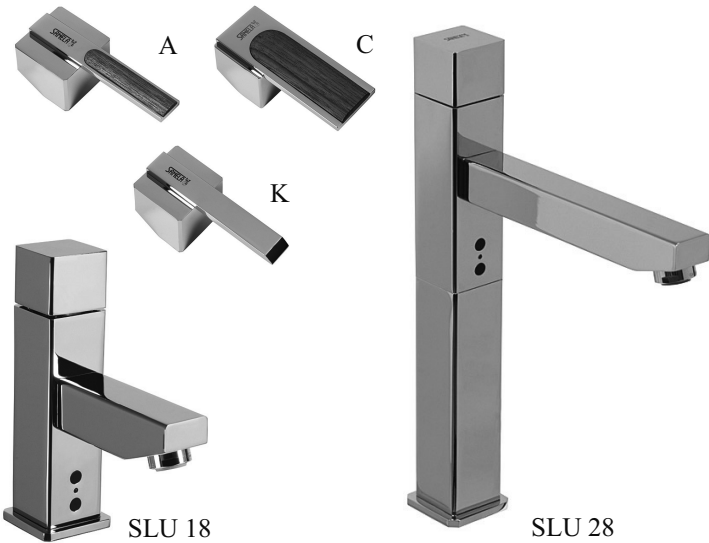

Characteristics:

6 L

LEED

- economical aerator, rate of flow 6 l/min
- function of automatic water stop after 5 minut of continuous flow
- water is flowing as long as hands are in the active range (max. range to 0,3 m)
- water stops flowing after removal of hands from the active range of sensor after adjustable time delay
- time delay from 0,25 to 7,75 sec.
- possibility of changing of time delay, active range and switching off by SLD 03
- washbasin mixers are destined for cold and hot water, temperature is regulated by mixer
- monitoring of battery capacity (only for models with „B“ index)
- START/STOP program

Technical Specification:

Operation voltage

- SLU 18, 18A, 18C, 18K, 28, 28A, 28C, 28K 24V DC
- SLU 18B, 18AB, 18CB, 18KB, 28B, 28AB, 28CB, 28KB battery 9V

Power input

- operating voltage 24V DC 10 W
- operating voltage 9V 2,0 W

Battery life

- lithium 9V, typ U9VL approx. 2 years (100 uses per day)

Active range

- standard 0 - 0,3 m
- START/STOP program 0,05 - 0,1m

Recommended flow pressure

- 0,1 - 0,6 MPa

Rate of flow

- 6 l/min. (inf. data)

Water inlet

- male thread G 1/2"

Dimensions:

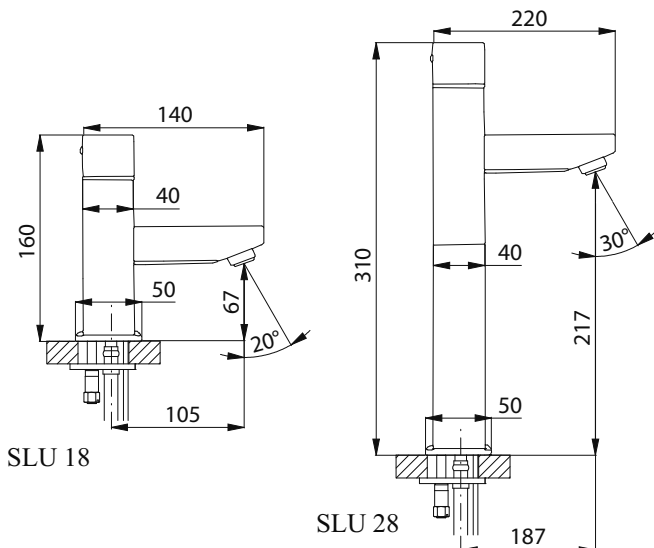

Supply Specification:

SLU 18	- supply No. 03180	chromium-plated faucet with an integrated electronics; battery holder (only for models with „B“ index); electromagnetic valve (2 pcs.); connecting hoses; angle valve with a filter and non-return valve (2pcs.); silicon sealing cement; lithium battery SLA 09 (only for models with „B“ index)
SLU 18A	- supply No. 43184	
SLU 18C	- supply No. 43182	
SLU 18K	- supply No. 13187	
SLU 18B	- supply No. 03185	
SLU 18AB	- supply No. 43185	
SLU 18CB	- supply No. 43183	SLU 28K - supply No. 13287
SLU 18KB	- supply No. 43181	SLU 28B - supply No. 03285
SLU 28	- supply No. 03280	SLU 28AB - supply No. 43285
SLU 28A	- supply No. 43284	SLU 28CB - supply No. 43283
SLU 28C	- supply No. 43282	SLU 28KB - supply No. 43281

Recommended Accessories:

SLZ 01Y	- supply No. 05012	external power supply 230/24V DC for operating of max. 1 pc. of washbasin tap (see page 118)
SLZ 01Z	- supply No. 05011	external power supply 230/24V DC for operating of max. 2 pcs. of washbasin taps (see page 118)
SLZ 03	- supply No. 05030	switched power supply 230/24V DC for operating of max. 4 pcs. of washbasin taps (see page 118)
SLD 03	- supply No. 07030	universal remote control for an adjustment of parameters of all products with infra-red electronics (see page 115)
SLA 09	- supply No. 06090	lithium battery 9V/1200 mAh, type U9VL, battery life approx. 2 years at 100 uses per day (only for models with „B“ index) (see page 115)